

**MATERIALS:**

1. CONCRETE: MIN. 5000 psi @ 28 DAYS
2. REBAR: ASTM A615 GRADE 60
3. CARRIAGE BOLTS: ASTM F1554 GRADE 55
4. ANCHOR PLATES: ASTM A514
5. BEARING PLATES: ASTM A36
6. NUTS: ASTM A194 GRADE 2H
7. WASHERS: ASTM F436

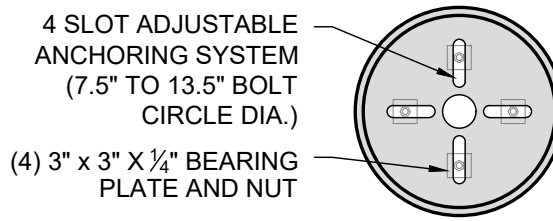

**TOP VIEW**  
SCALE: 1/2" = 1'-0"

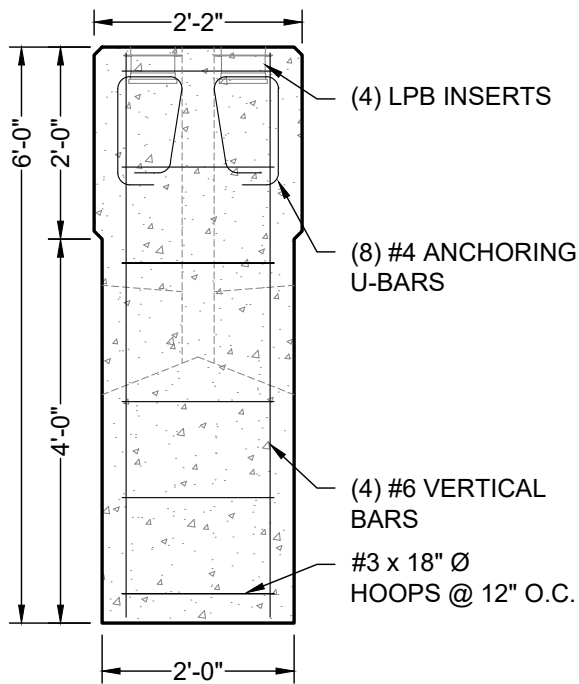

**PRODUCT SECTION VIEW**  
SCALE: 1/2" = 1'-0"

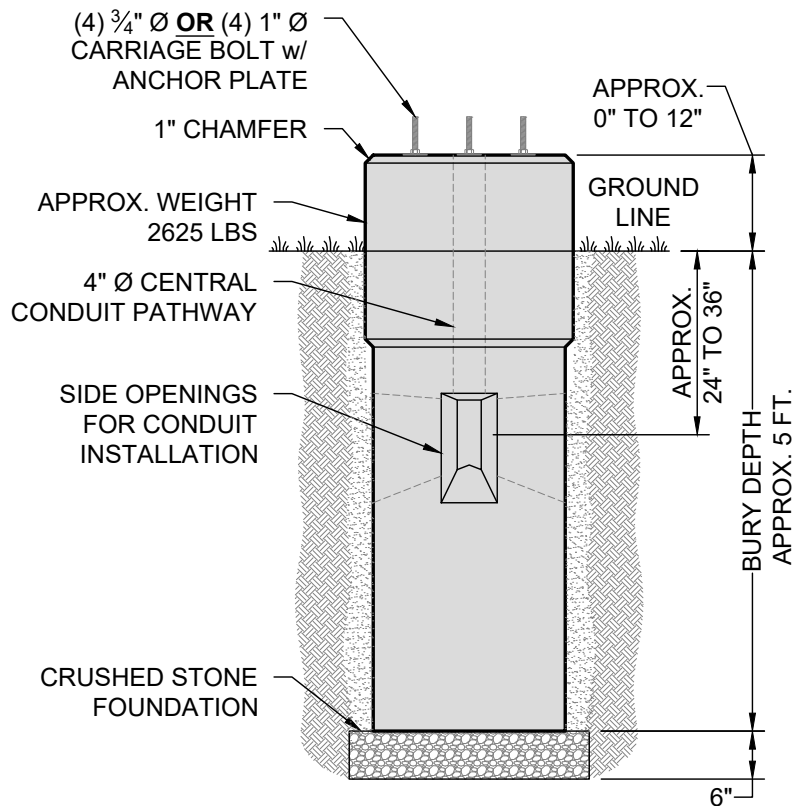

**INSTALLED PRODUCT VIEW**  
SCALE: 1/2" = 1'-0"

Disclaimer: This drawing has been prepared by LPB, A Forte Company, and to the best of its knowledge, accurately represents the product use in the application that it is illustrated. This drawing is intended for conceptual purposes only. Anyone making use of this drawing does so at their own risk and assumes all liability for such use. Final design for construction purposes must be completed by a Registered Professional Engineer who is familiar with the product and who has taken into account specific site conditions.



**LPB CLASSIC  
C-6.12**

Eull's Manufacturing  
Phone: 763.497.2742  
email: sales@eullsmfg.com  
www.lightpolebase.com