

NOVUM WALL™

NOVUM WALL - ALPINE TEXTURE



For gravity walls up to 6' tall, and the ability to use geo-grid for taller walls, Novum is the Wetcast, Machine-set block solution for your retaining wall needs. Fast installation keeps project costs low, while Superior Durability, and unique aesthetics with 9" block height give owners long-term satisfaction.





NOVUM BLOCK SPECIFICATIONS

- STACKED STONE TEXTURE
- 2.88 SQUARE FEET OF FACE; 9" TALL
- UNIQUE FACES TO GIVE WALLS A RANDOM AESTHETIC APPEARANCE
- WET-CAST CONCRETE GIVES A GREATER LEVEL OF DETAIL AND DURABILITY
- MACHINE-SET BLOCK FOR CONTRACTOR EASE AND SPEED (2 TO 3 PERSON CREW)
- 610 LBS. PER BLOCK

**SEE HOW NOVUM
CAN ELEVATE
YOUR PROJECT!**

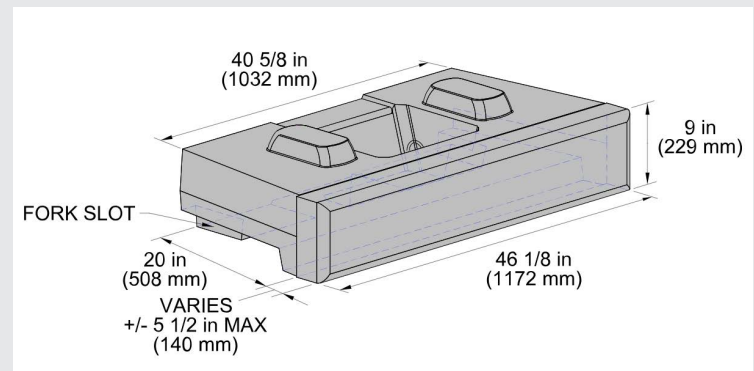

LOCALLY PRODUCED BY

Randy Nelson
Sales Representative
612.816.9845
rnelson@eullsmfg.com



Eull's Manufacturing
3187 LaBeaux Ave NE
St. Michael, MN 55376
office phone: 763.497.2742
e-mail: sales@eullsmfg.com
www.eullsmfg.com

VISIT NOVUMWALL.COM FOR MORE RESOURCES